



OPERATING MANUAL

SESAM 800 PIN

L99, RX, RXD, RX DIN



Table of Contents

1	Introduction	4
2	Scope	4
3	Service	4
4	Maintenance	4
5	Technical Specifications	5
6	Description of the System	6
6.1	<i>Receivers</i>	6
6.2	<i>Transmitter</i>	7
7	Description of the Receivers	7
8	Installation of the Receiver	10
8.1	<i>Placement of the Receiver</i>	10
8.2	<i>Antenna Placement</i>	11
8.3	<i>Connections on the Receiver (all models)</i>	11
9	Indicators on the Receivers	12
9.1	<i>Sesam 800 RX</i>	12
9.2	<i>Sesam 800 RXD</i>	12
9.3	<i>Sesam 800 RX DIN</i>	13
10	Configuration of the Receiver	13
10.1	<i>Sesam 800 RX</i>	13
10.2	<i>Sesam 800 RXD</i>	14

10.3 Sesam 800 RX DIN	18
10.4 High Security Transmission Mode	19
10.5 Memory Card (only Sesam 800 RXD)	19
11 Description of the Sesam 800 L99 PIN	22
11.1 Indications on the Transmitter	23
12 Using the System	23
13 Configuration of the Transmitter	24
13.1 Group ID	24
13.2 Display Window Illumination	25
13.3 PIN-lock	25
13.4 Receiver selection lock/unlock	26
14 Replacing Batteries in the Transmitter	27
15 Error Codes	28
Error codes, Sesam 800 RXD	28
Error codes, Sesam 800 RX and RX DIN	28
Error Codes Sesam 800 L99	28
16 Receiver Drill Measure for RX and RXD	29
16.1 Measure for RX DIN	29
17 Transmitter Drill Measure	30

1 Introduction

This manual only covers the installation of the Sesam radio remote door opening system. The Sesam System is not a complete door opening system: it provides only the set of outputs that are driven according to the actions performed by the operator of the transmitter. The way the set of outputs is used for controlling the doors depends on the specific installation and is outside the scope of the Sesam.

The approvals that the Sesam radio remote control system is only valid for the system itself.

The complete remote control system, where the controlled object is one part, has to be tested and approved according to the standards/norms that are applicable and specific to the controlled object. It is not the responsibility of Åkerströms Björbo.

2 Scope

The following guide must be used when installing Åkerströms Sesam door opening system to ensure secure, safe operation. The installation must be carried out by a certified electrician.

3 Service

Contact your Åkerströms Björbo AB dealer for service or support. Warranty work must be performed by Åkerströms or authorized service center.

4 Maintenance

For cleaning use a dry cleaning cloth, if necessary use a wet cleaning cloth and a soap solution. Never use an alcohol-based product for cleaning; it can seriously damage the plastic. Do not use pressure washer on the product!

5 Technical Specifications

Table 1. Technical Specifications, Sesam 800 RX RXD DIN L99

System Specifications	
Operating frequency:	869,8 MHz
Channel separation:	25 kHz
Power output:	< 5 mW
Functional sensitivity:	≤ -107 dBm BER 10-4
Transmission principle:	GMSK, TDMA,
Operating Temperature:	-25°C - +55°C
Storage Temperature:	-40°C - +85°C
RX & RXD specifications	
IP- class:	IP65
Power Supply, 12-24 V DC versions:	12-24 V DC/AC 150 mA (SELV), 4AT fuse.
Power Supply, 230 V AC versions:	230 V AC 50 Hz 15 mA, 4AT fuse.
Max switching capacity of relays:	2A/250 V AC with $\cos\phi=1$
Total load on all relays:	4A/250 V AC (not exceeding 2A on any single relay)
Relay- type	SPDT
Fuse on current loop:	2,5AT/250 V AC (IEC 60127-2/V)
Dimensions: (for more detail see chap. 15)	135 x120 x 50 mm
Weight:	450g
Screw Size:	TX20
DIN specifications	
Power Supply	12-24 V AC/DC
Max switching capacity of relays:	2A/250 V AC with $\cos\phi=1$
Fuse on current loop:	2,5AT/250 V AC (IEC 60127-2/V)
Dimensions:	92 x72,5 x 30 mm
Weight:	84g

L99 Specifications	
IP- class:	IP67
Dimensions:	120x75x30
Weight:	200g
Battery type:	2*AA Alkaline
Screw Size:	PH2

6 Description of the System

6.1 Receivers

This document covers three receiver models. RX, RXD and RX DIN.
RX and RXD can be ordered as 230 VAC or 12-24 VAC/DC.
RX DIN only as 12-24 VAC/DC.

Sesam 800 RX:

- 3 Single Pole Double Throw relays.
- Memory capacity: up to 100 transmitters.

Sesam 800 RXD:

- 3 Single Pole Double Throw relays.
- Integrated display and configuration buttons.
- Memory capacity: up to 500 transmitters.
- The receiver can be equipped with an detachable memory card containing a backup of all configuration parameters.

Sesam 800 RX DIN:

- 3 Single Pole Double Throw relays.
- Memory capacity: up to 100 transmitters.
- Designed for DIN rail

6.2 Transmitter

This document covers the Sesam 800 L99 PIN transmitter.
Important features are:

- A transmitter suitable for controlling up to 1000 different doors.
- Integrated back lighted display
- Optional cassette with external power and antenna connectors
- PIN lock and receiver selection lock

7 Description of the Receivers

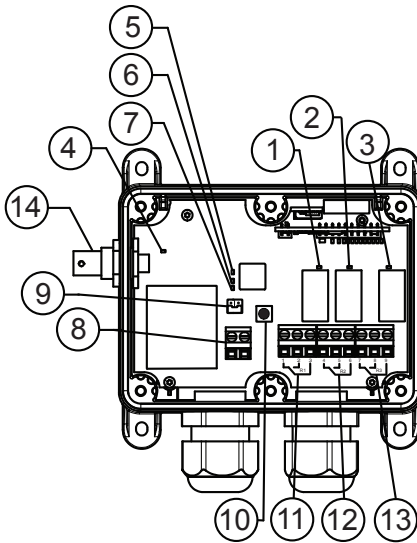

Figure 1. Sesam 800 RX 230 VAC model indicators, connections and jumper.

1. LED 1 Relay 1 status
2. LED 2 Relay 2 status
3. LED 3 Relay 3 status
4. LED 4 Power LED
5. LED 5 Squelch
6. LED 6 Status
7. LED 7 Learn
8. Power connection 230 VAC
9. Jumper J1 High Security
Transmission Mode setting
10. Learn/Erase button
11. Connection to relay 1, ARROW UP
12. Connection to relay 2, STOP
13. Connection to relay 3, ARROW DOWN
14. Antenna connector

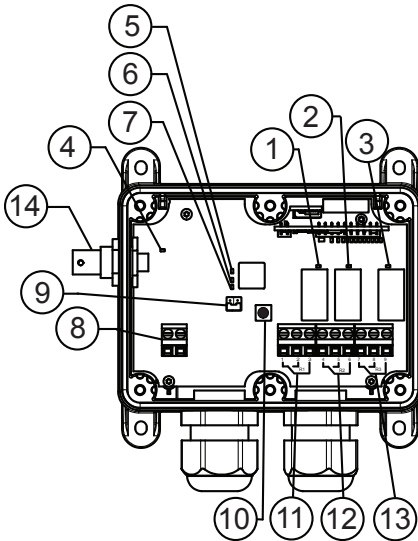

Figure 2. Sesam 800 RX 12-24 V DC model indicators, connections and jumper.

1. LED 1 Relay 1 status
2. LED 2 Relay 2 status
3. LED 3 Relay 3 status
4. LED 4 Power LED
5. LED 5 Squelch
6. LED 6 Status
7. LED 7 Learn
8. Power connection 12-24 V AC/DC
9. Jumper J1 High Security Transmission Mode setting
10. Learn/Erase button
11. Connection to relay 1, ARROW UP
12. Connection to relay 2, STOP
13. Connection to relay 3, ARROW DOWN
14. Antenna connector

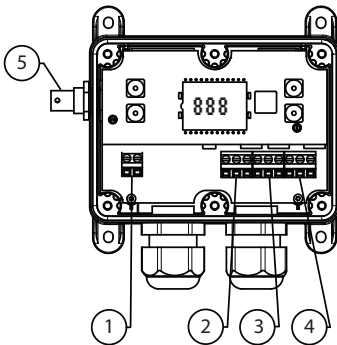

Figure 3. Sesam 800 RXD 12-24 V DC/AC model connections

1. Power connection
2. Connection to relay 1, ARROW UP
3. Connection to relay 2, STOP
4. Connection to relay 3, ARROW DOWN
5. Antenna connector

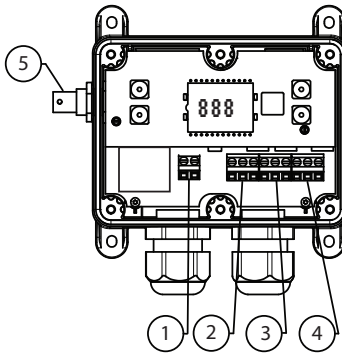

Figure 4. Sesam 800 RXD 230 V AC model connections

1. Power connection,
2. Connection to relay 1, ARROW UP
3. Connection to relay 2, STOP
4. Connection to relay 3, ARROW DOWN
5. Antenna connector

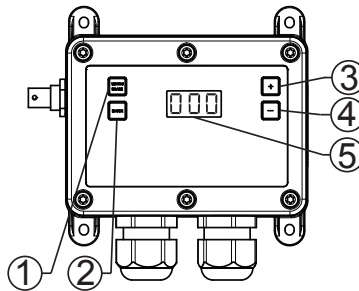

Figure 5. Sesam 800 RXD model display and buttons

1. Learn/Erase button
2. Enter button
3. Memory position up button
4. Memory position down button
5. Display

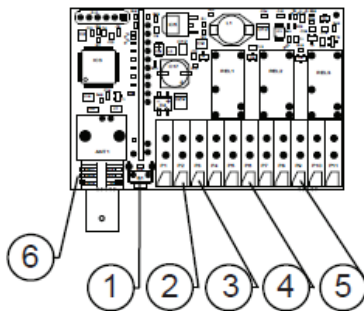

Figure 6. Sesam 800 RX DIN model connections and buttons

1. Learn/Erase button
2. Power connection,
3. Connection to relay 1
4. Connection to relay 2
5. Connection to relay 3
6. LED 5 Squelch
LED 6 Status
LED 7 Learn

8 Installation of the Receiver

The permanent installation of the receiver must include fuses that protect the equipment and wiring from overcurrent and short-circuit. In detail the power supply of the receiver and all relay contacts must be fused.

All fuses are used as disconnecting devices. The fuses shall be easily accessible, must submit a contact gap of at least 3.0 mm and have to be placed in the line pole. Note that the fuse must be compatible with IEC 60127-2/V.

After the installation of the equipment, the installed cables must be bound together (i.e. by using a cable binder) very close to the terminal blocks.

Note that there might be hazardous voltage in the receiver, therefore only certified electricians are allowed to open the lid.

8.1 Placement of the Receiver

Select a location that is within the environmental limitations of the receiver and where it is difficult for unauthorized persons to obtain access to the receiver. If possible, mount the receiver with the cable glands facing downwards.

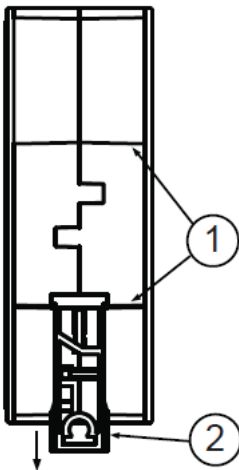

For the drilling measure of SESAM RX and RXD see chapter 16.

These receivers are preferably screwed with 4 mm screws suitable for the surface. Think of the antenna's size and influence of any metal objects when choosing placement.

SESAM RX DIN is to be mounted on a DIN rail. On the back there is a recess that the rail fits in (see 1 in Figure 7). When the recess is pressed against the rail the snap fit (see 2 in Figure 7) will lock the receiver to the rail automatically. Make sure that the snap . To remove, withdraw the snap fit and lift the receiver off the rail.

Figure 7. DIN receiver, the lock for the rail

8.2 Antenna Placement

Attach the supplied antenna to the antenna connector on the receiver. Note that the antenna must not be placed near metal objects such as wiring, tinroof, etc.

If an antenna cable is needed, contact Åkerströms Björbo AB.

8.3 Connections on the Receiver (all models)

The receiver is equipped with connections for relays, power and an external antenna (see chapter 7).

The connections for power connection are, from left to right:

- Line (L)
- Neutral (N)

The connections for each relay are, from left to right:

- Common terminal
- Normally opened (NO)
- Normally closed (NC)

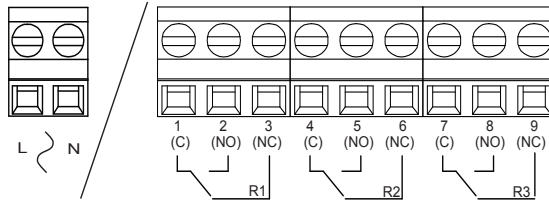

Figure 8. Power connection and Relay connection

Connection exemple:

- R1 = UP
- R2 = STOP
- R3= DOWN

9 Indicators on the Receivers

9.1 Sesam 800 RX

The Sesam 800 RX model has seven LED indicators that is displaying system information (see Figure 1 for positions of the LEDs).

The indications on the LEDs are as follows:

1. LED 1 Relay 1 status: LED ON indicates that the relay is active.
2. LED 2 Relay 2 status: LED ON indicates that the relay is active.
3. LED 3 Relay 3 status: LED ON indicates that the relay is active.
4. LED 4 Power: Indicates whether the receiver is powered on or not.
5. LED 5 Squelch: Indicates a detected signal on the operating frequency band.
6. LED 6 Status: Indicates that information from a transmitter associated with the receiver has been received.
7. LED 7 Learn: Indicates if the transmitter is in Learn Mode.

9.2 Sesam 800 RXD

The Sesam 800 RXD model has an integrated display that shows additional system relevant information (see Figure 5).

At activation of a certain function, the transmitter memory position will be shown in the display window.

If a relay is activated, the following will be shown in the display:

- Left decimal point: Relay 1 activated.
- Both decimal points: Relay 2 activated.
- Right decimal point: Relay 3 activated.
- Number of used memory position.

At start up, the display will show system information in the following order:

- System version.
- “E r d” if a memory card is installed.
- Programmed door number.

9.3 Sesam 800 RX DIN

The Sesam 800 RX DIN model has three LED indicators that is displaying system information (see Figure 6 for positions of the LEDs).

The indications on the LEDs are as follows:

1. LED 5 Squelch: Indicates a detected signal on the operating frequency band.
2. LED 6 Status: Indicates that information from a transmitter associated with the receiver has been received.
3. LED 7 Learn: Indicates if the transmitter is in Learn Mode.

10 Configuration of the Receiver

10.1 Sesam 800 RX

10.1.1 Basic Configuration

1. Open the lid on the receiver (6 TX20 screws).
2. Choose the door number that shall be used (0-999) and enter the number on the transmitter.
3. Press the “Learn/Erase” button until LED 7 is ON. The Learn Mode will be active for 10 seconds (as long as LED 7 is ON).
4. Press UP on the transmitter, LED 7 flashes 3 times if the Learn is successful.
5. Mount the lid on the receiver. Tighten the screws with TX 20 torque 2,0 Nm.

10.1.2 Erasing All Transmitters in the Receiver SESAM 800 RX

1. Open the lid on the receiver (6 TX20 screws).
2. Press the “Learn/Erase” button until LED 7 is ON.
The Learn Mode will be active for 10 seconds.
3. Press the “Learn/Erase” button for 5 seconds (until LED 7 is OFF).
All transmitters are now erased from the receiver memory.
4. Mount the lid on the receiver. Tighten the screws with TX 20 , 2,0 Nm.

10.2 Sesam 800 RXD

10.2.1 Basic Configuration

1. Choose the door number that shall be used (0-999) and enter the number on the transmitter.
2. Press the “Learn/Erase” button.
The display window shall show “L r n” followed by the memory position that the transmitter will be stored in.
The right decimal on the display flashes as long as the Learn mode is active (10 seconds).
3. Press ARROW UP on the transmitter.

The display shows “A [] []” if the learn process is successful and the receiver will return to normal operating mode automatically. The display will now show the new door number.

10.2.2 Advanced Configuration

This configuration allows the user to choose at what memory position a certain transmitter shall be stored in.

Adding a transmitter in a certain memory position

1. Press the “Learn/Erase” button.

The display window shall show “L r n” followed by the memory position that the transmitter will be stored in.
The right decimal on the display flashes as long as the Learn mode is active (10 seconds).
2. To select what memory position to use (memory positions can be 1-500) press the Memory Position UP or Memory Position DOWN buttons (see Figure 5). The left decimal on the display indicates whether the chosen memory position is already used.
3. Press ARROW UP on the transmitter.

The display will show “A [] []” and will return to normal operating mode.

10.2.3 Erasing Transmitters in the Receiver SESAM 800 RXD

Erasing individual transmitters

1. Press the “Learn/Erase” button.

The display shows “L r n” followed by the memory position that will be erased. This mode will be active for 10 seconds.

2. Change what memory position to delete (1 to 500) by using “+” and “-” buttons.

The left decimal in the display window indicates whether the memory position is in use or not (note that two decimals are shown in the display).

3. Press the “Learn/Erase” button to remove the selected memory position.

The display will show “DEL” and return to normal operation.

Erasing all transmitters

1. Press the “Learn/Erase” button.

The display shows “L r n” followed by the memory position that will be erased. This mode will be active for 10 seconds.

2. Press the “Learn/Erase” button for 5 seconds to erase all memory positions.

The display will show “DEL” “ALL” and return to normal operation.

All transmitters are now erased from the receiver memory and, if connected, the memory card.

10.2.4 Re- configuring a Transmitter in the Receiver SESAM 800 RXD

If the user attempts to program a transmitter that is already programmed in the receiver, the display will show “E r l” followed by the original memory position on the display.

Erase the original memory position before proceeding with the configuration.

10.2.5 PIN Lock in the Receiver SESAM 800 RXD

The Sesam 800 RXD can be protected from unauthorized configuration by using a 4-digit PIN-code.

When a PIN-code is configured, all buttons on the receiver are locked except the button used to enter the code (Enter button).

To configure the PIN-lock do the following:

- Power on the receiver.
- Press the Enter button and hold it down for 5 seconds. The display should now show “Pin new” followed by “_ _ _”. If the user is inactive for more than 10 seconds in the PIN configuration mode the receiver will return to normal operations.
- Enter the first digit of the code by using the ‘+’ and ‘-’ buttons. Press the ‘Enter’ button when finished.
- Repeat the above step for digit 2..4.
- When all 4 digits are entered the display will show ‘rpt’ (repeat). The code must be repeated to be accepted. Enter the code once more.
- If the code is entered successfully the display will show ‘Sto’ (stored).
- The receiver will automatically be locked after 10 seconds of button inactivity. The display will show “LOC” when the receiver switches to locked mode.

To unlock the receiver do the following:

- Press the Enter button and hold it down for 5 seconds. The display should now show “Pin” followed by “_ _ _”. If the user is inactive for more than 10 seconds in the PIN configuration mode the receiver will return to normal operations.
- Enter the first digit of the code by using the ‘+’ and ‘-’ buttons. Press the ‘Enter’ button when finished.
- Repeat the above step for digit 2..4.
- When all 4 digits are entered correctly the display will show ‘PAS’ (passed) and the buttons on the receiver will be unlocked for 60 seconds. If the PIN is incorrect the display will show ‘Err’.
- The receiver will automatically be locked after 60 seconds of button inactivity. The receiver can also be manually locked by pressing the Enter button for 5 seconds. The display will show “LOC” when the receiver switches to locked mode.

To change /delete Receiver PIN do the following:

- The PIN can only be changed by unlocking the receiver and making a “delete all” erasing all configurations on the receiver.

MC Manager Compatibility:

In the new version of the MC Manager PC application version 1.1 there is an additional field for PIN code. This allows the user to pre-configure receiver PIN.

If a memory card is pre-configured with a PIN that is identical to the PIN in the receiver an automatic copy will be done from the memory card to the receiver at start-up.

A lost receiver PIN-code can be retrieved with the MC manager.

10.3 Sesam 800 RX DIN

10.3.1 Basic Configuration

1. Open the lid on the receiver. Open the lid of the receiver by pressing the snap fits on the sides with a screwdriver or similar and pull apart the cover.
2. Choose the door number that shall be used (0-999) and enter the number on the transmitter.
3. Press the Learn/Erase button until LED 7 is ON. The Learn Mode will be active for 10 seconds (as long as LED 7 is ON).
4. Press UP on the transmitter, LED 7 flashes 3 times if the Learn is successful.
5. Mount the receiver cover by match top and bottom together and press, the snap fits on the sides locks.

10.3.2 Erasing All Transmitters in the Receiver SESAM 800 RX DIN

1. Open the lid on the receiver.
2. Press the Learn/Erase button until LED 7 is ON. The Learn Mode will be active for 10 seconds.
3. Press the Learn/Erase button for 5 seconds (until LED 7 is OFF). All transmitters are now erased from the receiver memory.
4. Mount the lid on the receiver.

10.4 High Security Transmission Mode

The High Security Transmission Mode uses encrypted authentication to ensure that the receiver only replies to commands from transmitters stored in the memory. This mode makes it difficult to scan and record messages that could, with the right technology, open doors without using an authentic coded transmitter.

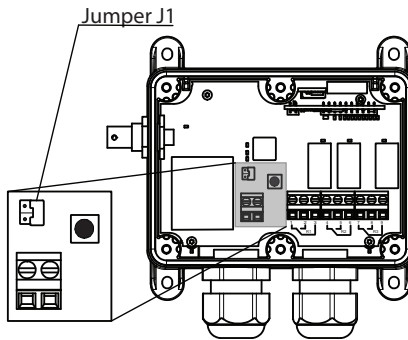

Figure 9. Jumper J1 shown with high security transmission mode enabled.

To enable the High Security Transmission Mode, close jumper J1 (see Figure 9) and restart the receiver. At startup, the display will show “S E P”.

The high security mode will slightly increase the response time and reduce the operating range.

10.5 Memory Card (only Sesam 800 RXD)

A memory card is useful in applications where many transmitters are used to control one single receiver. The receiver can be equipped with a detachable memory card containing a backup of all configuration parameters.

If a receiver needs replacement, the user only has to install a new receiver of the same type and insert the memory card in the new receiver in order to get the same functionality as in the old receiver.

If more receivers with the same configuration are needed, remove the card and perform the copy operation on a new receiver.

10.5.1 Copying Information from a Memory Card to a New Receiver

1. Turn the power off the receiver.
2. Unscrew the 6 screws holding the receiver lid.
3. Carefully remove the display card.
4. Insert the memory card that you want to copy in the memory card slot in the receiver (see Figure 10).
5. Mount the display card in the display card slot (see Figure 10).
6. Start the receiver.

The display will show “CPY” when the copy operation is completed.

Note that the memory in the receiver has to be empty before copying the memory card to the receiver (see chapter 10.2.3 for information on how to delete the memory).

7. If the memory card will be used to copy the configuration on to other receivers or if the memory card shall be used as a backup, remove it. If not, mount the lid and tighten all screws with TX 20, torque 2,0 Nm.

10.5.2 Copying Information from a Receiver to a Memory Card

Note that the memory card has to be empty before copying the receiver memory to the card. To remove information from a memory card, insert the card in a new receiver and erase all transmitters (see chapter 10.2.3).

1. Turn the power off the receiver.
2. Unscrew the 6 screws holding the receiver lid and remove the lid.
3. Carefully remove the display card.
4. Insert the memory card that you want to copy all parameters to in the memory card slot (see Figure 10).
5. Mount the display card in the display card slot (see Figure 10).
6. Start the receiver and wait for approx. 5 seconds.

The display will show “C P Y” “t” “CRD” when the copy operation is completed.

7. Remove the display card and the memory card. If the memory card shall be stored; store it in a clean environment free from static electricity.
8. Mount the display card and the lid. Tighten all screws with TX 20 torque 2,0 Nm.

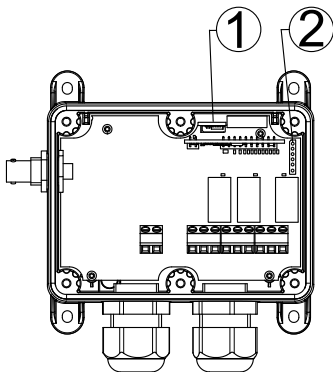

Figure 10. Memory card and display slots in the receiver

1. Memory card slot
2. Display slot

11 Description of the Sesam 800 L99 PIN

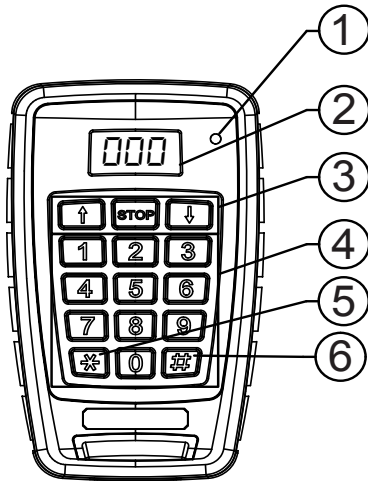

Figure 11. The Sesam 800 L99 PIN transmitter indicators and buttons.

1. Indicator LED.

2. Display

3. Function buttons

(from left to right ARROW UP, STOP, ARROW DOWN)

4. Numeric Entry

5. * Receiver selection lock/unlock

6. # Enable PIN lock

11.1 Indications on the Transmitter

11.1.1 LED Indicator

Normal operation

Quick flashing RED = sending message.

Continuous GREEN = Relay activated in the receiver
(Feedback information from receiver).

Battery warning

3 long RED flashes = Battery depleted, transmitter cannot send commands.

Continuous RED after activating command = Low battery.

11.1.2 Display

The display shows system- relevant information during start up and operation.

At startup, the transmitter software version followed by battery voltage is displayed. After this, the transmitter enters normal operation mode. In this mode, the display shows the door number that will be activated if any of the ARROW UP, STOP, ARROW DOWN buttons are pressed.

If the display indicates “L 0 b A T”, replace the batteries.

11.1.3 Buttons on the Transmitter

The transmitter is equipped with 15 buttons, namely ARROW UP, STOP, ARROW DOWN, buttons 0-9, * and #.

ARROW UP, STOP and ARROW DOWN buttons are used for controlling the door movements. 0-9 buttons are used for selecting what door to control.

The function buttons * and # are used for locking/unlocking the receiver selection and enabling the PIN lock respectively.

12 Using the System

In order to control a door, enter the door number using the transmitter buttons and press the desired function button (ARROW UP, STOP or ARROW DOWN). The buttons * and # can be used to either increase or decrease the value shown in the display respectively.

13 Configuration of the Transmitter

13.1 Group ID

All Sesam 800 transmitters have a factory pre-programmed unique identity (ID). This is a number between 1000000 and 16777214.

In addition to the pre-programmed unique ID, the Sesam L99 has support for Group ID. A group ID consists of a six digit number that the user can configure on the transmitter. Transmitters with the same Group ID is considered identical by the controlled receivers. This means that transmitters can be organized in groups. This increases the flexibility and simplifies the maintenance on large installations. Each receiver is capable of learning/storing up to 500 Group IDs, one for each position on the memory card.

If no Group ID is configured, the transmitter will use factory ID settings.

13.1.1 Configuration of the Group ID in the Transmitter

1. Choose a suitable Group ID (either a new code, 000001 to 999999 or an group code already in use).
2. Remove the back side of the transmitter (see Figure 12).
3. Remove one battery.
4. Press the bottom left button (✱) on the transmitter while inserting the battery.
5. Continue pressing the button until the text “A i D” is displayed in the transmitter display.
6. Enter the six digit code using the keyboard (the transmitter LED will flash once for each button that is pressed).

After the entire code has been entered in the transmitter, the transmitter display will show “A i d” followed by the entered value.

7. Save the entered Group ID by pressing “#” button on the transmitter within 10 seconds.

If the Group ID has been accepted, the display window will show “S T D”.

8. Verify the transmitter functionality by testing the transmitter on a receiver with the correct Group ID.
9. Mount the back side of the transmitter (see Figure 14).

The transmitter can be restored to factory settings by entering “000000” as ID. For safety reasons, only group ID’s less than 100000 can be viewed using this configuration method.

13.2 Display Window Illumination

The display on the Sesam L99 has built in automatic illumination that can be ON or OFF. Typically, the battery life will increase by turning the illumination OFF.

13.2.1 Configuration of the Display Window Illumination

1. Remove the back side of the transmitter (see Figure 12).
2. Remove one battery.
3. Press the bottom right button (**#**) on the transmitter while inserting the battery.
4. Continue pressing the button until the text “L e d” is displayed in the transmitter display.
5. The new settings (“ON” or “OFF”) will be shown in the display.
6. Verify the transmitter functionality.
7. Mount the back side of the transmitter (see Figure 14).

13.3 PIN-lock

The Sesam 800 L99 PIN transmitter can be protected from unauthorized use by using a 4-digit PIN-code. When a PIN-code is configured and activated, all transmitting functions on the transmitter are locked. The transmitter is compatible with the standard Sesam 800 L99.

13.3.1 To configure the PIN-lock do the following:

1. Power on the transmitter.
2. Press the ***** and **#** button simultaneously and hold them down for 3 seconds. The display should now show “Pin new” followed by “___”.
3. Enter a new 4-digit code using buttons 0..9. If the user is inactive for more than 10 seconds in the PIN configuration mode the transmitter will return to normal operations.
4. When all 4 digits are entered the display will show ‘rpt’ (repeat). The code must be repeated to be accepted. Enter the code once more.
5. If the code is entered successfully the display will show ‘Str’ (stored).
6. The transmitter will automatically be locked after 60 seconds of button inactivity. The display will show “Pin” when the transmitter switches to locked mode.

If a PIN code is configured the transmitter will always be locked after power-up.

13.3.2 To unlock the transmitter do the following:

1. If the transmitter is locked the display will show 'Pin'.
2. Enter the 4-digit PIN using buttons 0..9. If the user is inactive for more than 10 seconds in the PIN entry mode the transmitter display will show 'Pin' again.
3. When all 4 digits are entered correctly the display will show 'PAS' (passed) and the buttons on the transmitter will be unlocked for 60 seconds. If the PIN is incorrect the display will show 'Err'.
4. The transmitter will automatically be locked after 60 seconds of button inactivity. The transmitter can also be manually locked by pressing the '*' button for 3 seconds. The display will show "Pin" when the transmitter switches to locked mode.
5. If a wrong PIN is entered 10 times in a row the transmitter will be locked for 5 minutes. During this time the display will show 'LOC'.
To unlock a transmitter without a PIN the unit has to be returned to Åkerströms for a factory reset.

13.3.3 To change /delete the transmitter PIN do the following:

1. Unlock the transmitter using the above method if necessary.
2. Press the '*' and '#' button simultaneously and hold them down for 3 seconds. The display should now show "Pin Old" followed by "___".
3. Enter the old 4-digit PIN using buttons 0..9. If the user is inactive for more than 10 seconds in the PIN configuration mode the transmitter will return to normal operations.
4. Enter a new 4-digit code using buttons 0..9. If you want to delete/disable the PIN lock enter 0000 as the new PIN.
5. When all 4 digits are entered the display will show 'rpt' (repeat). The code must be repeated to be accepted. Enter the code once more.
6. If the code is entered successfully the display will show 'Sto' (stored).

13.4 Receiver selection lock/unlock

Up to 1000 receivers can be addressed from the transmitter.

The number on the display indicates the current receiver selection.

The selected receiver number can be locked if only one receiver is used in the system. To lock the receiver selection press the '* key for 3 seconds. The display will indicate LOC on when the lock is active. Press the '* button again for 3 seconds to unlock.

14 Replacing Batteries in the Transmitter

If the display on the transmitter indicates “L b AT”, replace the batteries promptly. Note that changing of batteries must take place in a clean environment free from static electricity.

The batteries are changed as follows:

1. Open the battery cover by unscrewing the 6 screws on the backside of the transmitter housing (see Figure 12).
2. Carefully remove the cover by lifting up the front end of the cover (see Figure 14).
3. Remove the batteries.
4. Insert the new batteries.
5. Close the cover by first inserting the backside of the cover in the transmitter, and then pressing the front down (see Figure 14).
6. Tighten the 6 screws with PH2 (torque 1 Nm).

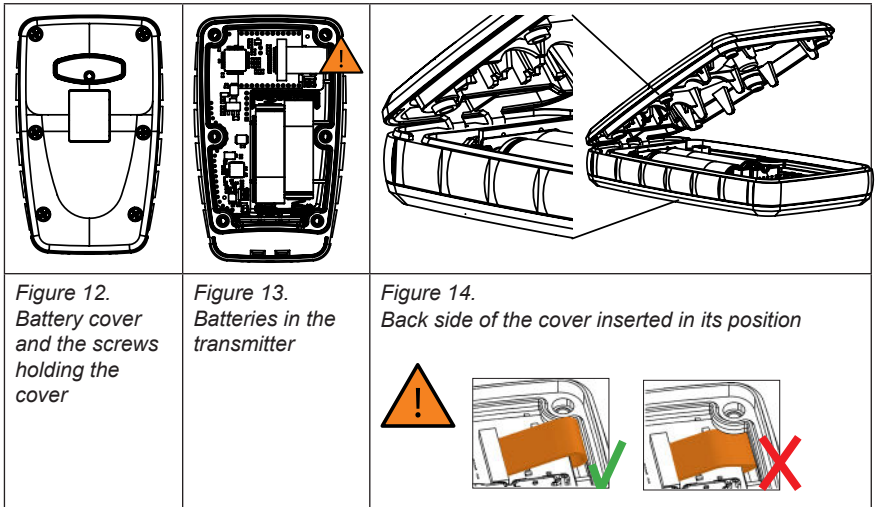

15 Error Codes

The Sesam 800 receivers can display some error codes. The error code depends on the model of the receiver.

Error codes, Sesam 800 RXD

Table 2. Error codes Sesam 800 RXD

ID already programmed	1
Memory full	2
Memory card mismatch during power up	10
Memory card write error. Maybe the memory card has been removed during operation.	11
Memory card copy to verify error	12
Internal errors. The unit needs service	3, 5 30, 31 and 32
Line power unstable	4

Error codes, Sesam 800 RX and RX DIN

Any of the above error states is displayed with ten quick flashes on the Status LED (LED 6) regardless of fault.

Error Codes Sesam 800 L99

Setting Group ID, timed out =1

Buttons stuck at start-up =6

If any other error codes are displayed, the transmitter needs service by an authorized service engineer.

16 Receiver Drill Measure for RX and RXD

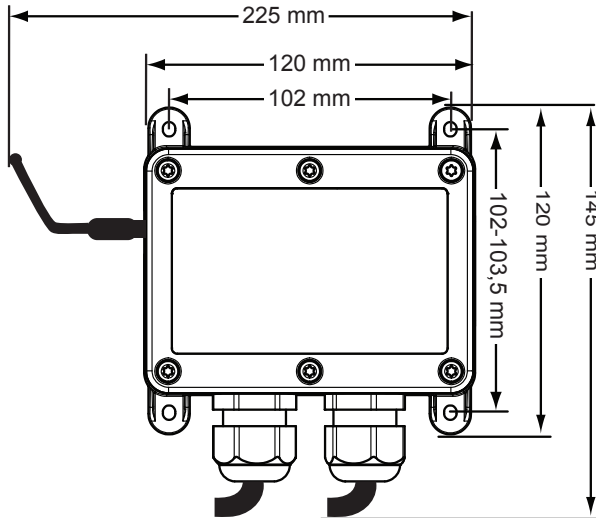

Figure 15. The receiver shall be attached with 4 mm screws that are suitable for the surrounding environment

16.1 Measure for RX DIN

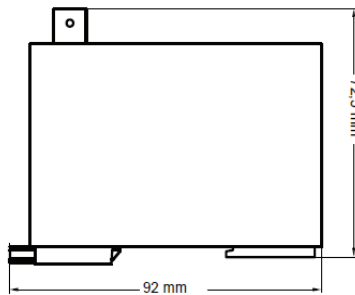

Figure 16. The DIN receiver measure

17 Transmitter Drill Measure

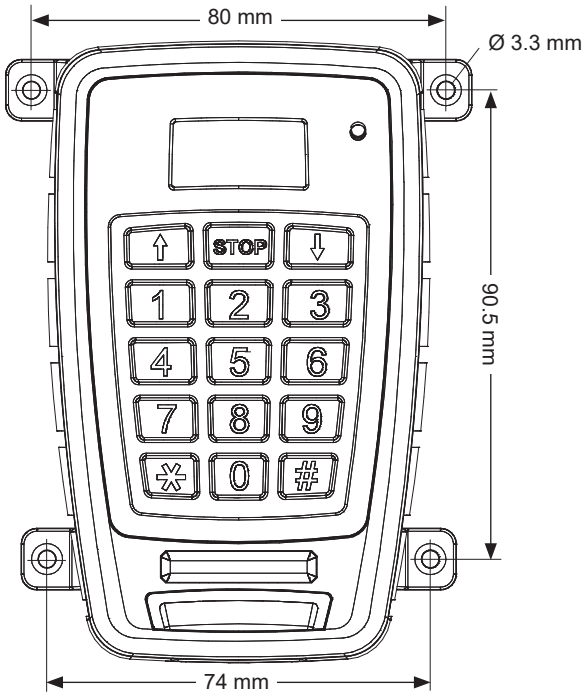

Figure 17. The transmitter shall be attached with screws that are suitable for the surrounding environment



Åkerströms Björbo AB

Postal address (for letters and invoices): Box 27, SE-786 21 Vansbro

Visiting address (for packages and deliveries): Björbovägen 143, SE-786 97 Björbo

www.akerstroms.com | Phone +46 241 250 00 | frontoffice@akerstroms.se