



OPERATING MANUAL

SESAM 800 MOBILE

WINCH

M6, M4, RXM



Table of Contents

1	Introduction	4
2	Scope	4
3	Service	4
4	Maintenance	4
5	Technical Specifications	5
6	Short Description of the System	6
6.1	<i>Receiver</i>	6
6.2	<i>Transmitters</i>	6
6.3	<i>Screw Sizes</i>	6
7	Description of the Receivers	7
8	Description of the Receivers to ATV Winch	8
8.1	<i>Installation of the Assembled Connection Cable</i>	9
8.2	<i>Installation of Non-assembled Cables</i>	10
8.3	<i>Cable Control</i>	13
9	Description of the Receivers to Forestry Winch	14
9.1	<i>Installation of the Assembled Connection Cable</i>	15
9.2	<i>Installation of Non-assembled Cables to Forestry Winch</i>	16
10	Indicators on the Receiver	18
10.1	<i>LED Indicators</i>	18
11	Installation of the Receiver	20
11.1	<i>Mounting Steps:</i>	20
12	Description of the Transmitter	23
13	Indications on the Transmitter	24
13.1	<i>Normal Operation</i>	24
13.2	<i>Battery Warning</i>	24
14	Operation	24
14.1	<i>Activating the Transmitter</i>	24
14.2	<i>Deactivating the Transmitter</i>	25
14.3	<i>Controlling the Device</i>	25
15	Receiver Drill Measures	26
16	Replacing Batteries in Sesam 800 M6 & M4	27

List of figures

Figure 1.	Sesam 800 RXM 12/24 V DC to ATV winch with cable installed..	8
Figure 2.	Sesam 800 RXM 12/24 V DC to ATV winch without cable	10
Figure 3.	Jumper in the left position and lower position.	13
Figure 4.	Sesam 800 RXM 12/24 V DC to Forestry winch with cable installed..	14
Figure 5.	Sesam 800 RXM 12/24 V DC to Forestry winch without cable	16
Figure 6.	Configuring internal supply of output power	21
Figure 7.	Sesam 800 M6 transmitter indication and buttons.	23
Figure 8.	Sesam 800 M4 transmitter indication and buttons.	23
Figure 9.	Receiver Drill Measures	26
Figure 10.	Battery cover and the screws holding the cover	27
Figure 11.	Batteries inserted in the transmitter.	27
Figure 12.	Backside of the cover inserted in its position	27

List of tables

Table 1.	Technical Specification, Sesam 800 Mobile	5
Table 2.	Connection Cables with contact art.no: 942867-000	9
Table 3.	Connection Cables without contact art.no: 942867-001	9
Table 4.	Color on cable	15
Table 5.	Output LEDs connected to the functions	19
Table 6.	LED's on input card	19
Table 7.	Output LEDs connected to the functions	19
Table 8.	Relationship between buttons and outputs	21

1 Introduction

This manual only covers the installation of the Sesam radio remote winch control system. The Sesam does not implement a complete control system: it provides only the set of outputs that are driven accordingly to the actions performed by the operator of the transmitter. The way the set of outputs is used for controlling the outputs depends on the specific installation and is out of the scope of the Sesam 800 Mobile system.

The complete remote control system, where the controlled object is one part, has to be tested and approved according to the standards/norms that are applicable and is not a part of Åkerströms Björbo's responsibility

2 Scope

The following guide must be used when installing Åkerströms Sesam winch control system to ensure secure, safe operation.

The installation must be carried out by a competent, suitable technically qualified person.



= This symbol highlights extremely important information

3 Service

Contact your Åkerströms Björbo AB dealer for service or support. Warranty work must be performed by Åkerströms or authorized service center.

4 Maintenance

For cleaning use a dry cleaning cloth, if necessary use a wet cleaning cloth and a soap solution. Never use an alcohol-based product for cleaning; it can seriously damage the plastic. Do not use pressure washer on the product!

5 Technical Specifications

Table 1. Technical Specification, Sesam 800 Mobile

System specification	
Operating frequency band:	869.7-870.0 MHz
Channel separation:	25 kHz
Power output:	<5 mW
Functional sensitivity:	Better than -107 dBm BER 10 ⁻⁴
Transmission principle:	GMSK, TDMA,
Operating Temperature:	-25°C - +75°C
Storage Temperature:	-40°C - +85°C
Receiver specifications	Sesam 800 RXM
IP- class:	IP67
Power Supply	12/24 V DC 25 mA (SELV), Must be fused with a 3A blade fuse.
Max switching capacity of outputs:	3A/24 V DC
Total load on all outputs:	3A/24 V DC
Dimensions:	120 x120 x 50 mm
Weight:	450g
Screw size (enclosure):	TX20
Transmitter specifications	Sesam 800 M6 & M4
IP- class:	IP67
Dimensions:	100 x 60 x 25 mm
Weight:	130g
Battery type:	2*AA/LR06 Alkaline
Power consumption:	15 mA during transmission
Screw size (enclosure):	PH2

6 Short Description of the System

6.1 Receiver

Main features:

- 6 outputs.
- Waterproof (IP67). Applies only those supplied with installed cable.
- Possibility to control the outputs by external connections, applies only the ATV winch.

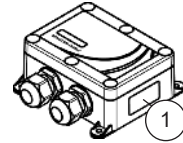

6.2 Transmitters

There are two different transmitters that can be used for winching applications:

Medium M4 a medium size 4- button transmitter suitable for one winch.

Medium M6 a medium size 6- button transmitter suitable for two winches.

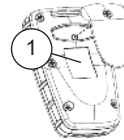

① Type label position

6.3 Screw Sizes

Receiver: Torx TX 20, torque 2.0 Nm.

Transmitter M6 & M4: Phillips Screw PH 2, torque 1.0 Nm.

7 Description of the Receivers

There are two different receivers for winch system.
They come in some different variations.

Receivers to ATV winch

- With assembled cable with plug (IP67)
- With assembled cable without plug (IP67)
- Without cable (not guaranteed IP67)

Receivers to Forestry winch

- With assembled cable (IP67)
- Without cable (not guaranteed IP67)

8 Description of the Receivers to ATV Winch

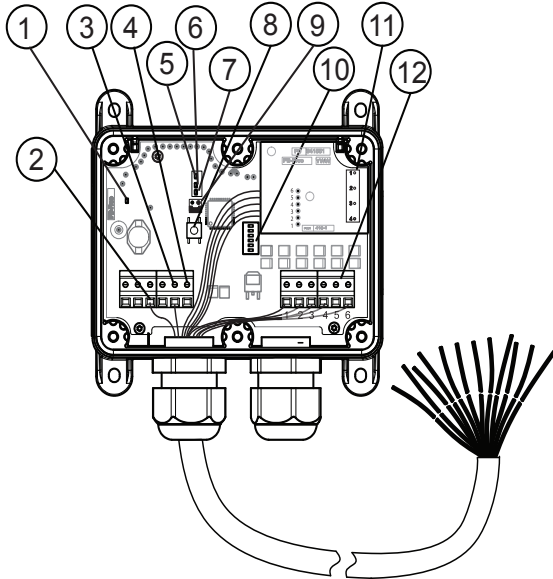

Figure 1. Sesam 800 RXM 12/24 V DC to ATV winch with cable installed. The models indicators, connections and jumper.

1. Power LED
2. Ground, 0V (-)
3. 12/24 V DC power.
Fuse with 3A blade fuse near the battery.
4. Internal supply to the outputs (see section 8.1)
- 5-7. Status LEDs
8. Learn/Erase button
9. Jumper J1
10. Output LEDs
11. LEDs for cable control.
12. Output connections 1-6

8.1 Installation of the Assembled Connection Cable

The receiver is equipped with a 12 multicore cable for connection to the winch, voltage, etc. The cable is fused with a 3A blade fuse near the battery connection. There are two versions of cable.

Table 2. Connection Cables with contact art.no: 942867-000

Function	Text on cable
+12V line	1
Ground (-) 0 V	2
Winch 1 in	4
Winch 1 out	3
Winch 2 in	6
Winch 2 out	5
Ext winch 1 in	7
Ext winch 1 out	8
Ext winch 2 in	9
Ext winch 2 out	10
Remaining	11
Spare	12

Table 3. Connection Cables without contact art.no: 942867-001

Function	Text on cable
+12V line	1
Ground, (-) 0 V	2
Winch 1 in	4
Winch 1 out	3
Winch 2 in	6
Winch 2 out	5
Ext winch 1 in	7
Ext winch 1 out	8
Ext winch 2 in	9
Ext winch 2 out	10
Remaining	11
Spare	12

8.2 Installation of Non-assembled Cables

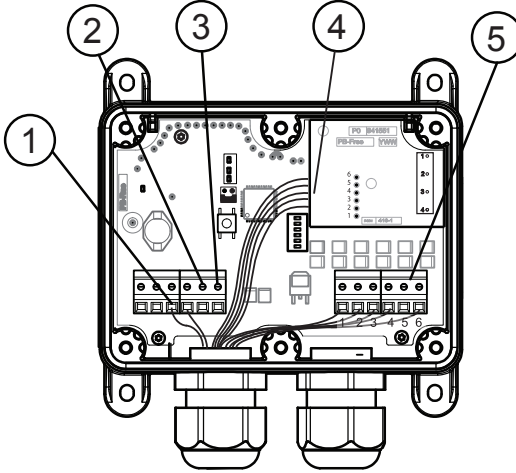

Figure 2. Sesam 800 RXM 12/24 V DC to ATV winch without cable

1. Ground, 0V (-)

2. 12/24 V DC power

Fuse with 3A blade fuse near the battery

3. Internal supply to the outputs (see section 8.1)

4. Outputs external card for cable control

5. Output connections 1-6

8.2.1 Installation of Non-assembled Cables to ATV Winch

For connection of cable, should at least a 12 conductor multicore cable with outer diameters of 6-12 mm be used. The cable must be specified for an outside temperature of +80°C and each conductor must be at least 0.75 mm². We recommend not having a longer cable than 5 meters. Power connection must be protected by a 3A blade fuse near the battery.

To connect to the input card the leaders have to be crimped with a crimping tool. The contact must be an AMPMODU * Mod.II Receptacle Contacts 280530-2 or equivalent.

Note that the cable is connected and crimped in accordance with IPC-A-620.

Functional diagram for installation of cable

- 12/24 V DC Power connection (see ② in Figure 2).
NOTE - fuse with 3A blade fuse near the battery.
- Ground, 0 V (-) (see ① in Figure 2).

Outputs/functions

- Output/Connection 1 - Winch 1 In.
- Output/Connection 2 - Winch 1 Out.
- Output/Connection 3 - Winch 2 In.
- Output/Connection 4 - Winch 2 Out.
- Output/Connection 5 - Spare.
- Output/Connection 6 - Remaining function ex. lamp.

8.2.2 Installation of External Inputs to ATV Winch

The receiver is equipped with four external inputs for manual cable control of in/out functions. These inputs have priority over radio control. To enable them see section 8.3.

To connect to the input card the leaders have to be crimped with a crimping tool. The contact must be an AMPMODU * Mod.II Receptacle Contacts 280530-2 or equivalent.

Note that the cable is connected and crimped in accordance with IPC-A-620.

- External Pin 1 - not used.
- External Pin 2 - Winch 1 In.
- External Pin 3 - Winch 1 Out.
- External Pin 4 - Winch 2 In.
- External Pin 5 - Winch 2 Out.
- External Pin 6 - Ground, 0 V (-).

8.3 Cable Control

The receiver outputs can be activated by using the cable control. If the cable control is used, all radio-controlled outputs will be blocked for 5 seconds after each command from the manual cable control.

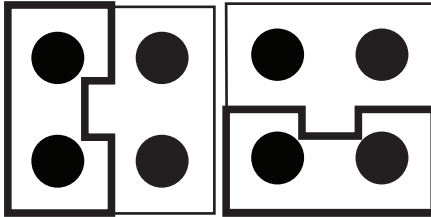

Figure 3. Jumper in the left position and lower position.

- To enable cable management place Jumper J1 in the left position.
- To disable the cable control place Jumper J1 in the lower position.

The recipient must be restarted for Jumper location to be updated.

9 Description of the Receivers to Forestry Winch

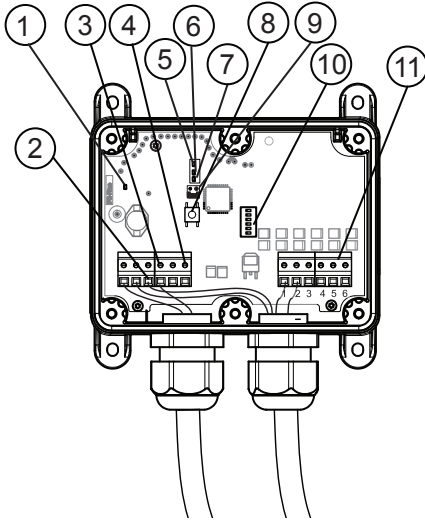

Figure 4. Sesam 800 RXM 12/24 V DC to Forestry winch with cable installed. The models indicators, connections and jumper.

1. Power LED
2. Ground, 0V (-)
3. 12/24 V DC power
Fuse with 3A blade fuse near the battery
4. Internal supply to the outputs (see section 8.1)
- 5-7. Status LEDs
8. Learn/Erase button
9. Jumper J1
10. Output LEDs
11. Output connections 1-6

9.1 Installation of the Assembled Connection Cable

The receiver is equipped with three cables, two with valve connectors and one voltage cable. The voltage cable is fused with a 3A blade fuse near the battery.

Table 4. Color on cable

Function	Color	Text on cable
+12V line	Brown	1
Ground (-) ,0V	Blue	2

9.2 Installation of Non-assembled Cables to Forestry Winch

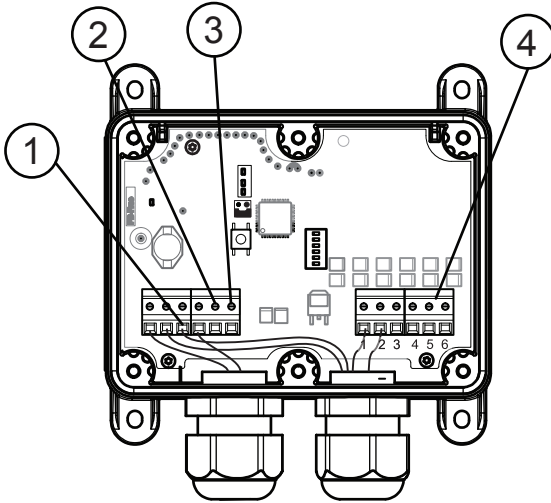

Figure 5. Sesam 800 RXM 12/24 V DC to Forestry winch without cable

1. Ground, 0V (-)

2. 12/24 V DC power.

Fuse with 3A blade fuse near the battery

3. Internal supply to the outputs (see section 8.1)

4. Output connections 1-6

9.2.1 Installation of Non-assembled Cables to Forestry Winch

For connection of cable, cable with outer diameters of 6-12 mm should be used. The cable must be specified for an outside temperature of +80°C and each conductor must be at least 0.75 mm². We recommend not having a longer cable than 5 meters. Power connection must be protected by a 3A blade fuse near the battery.

Functional diagram for installation of cable

- 12/24 V DC Power connection (see ② in Figure 5).
NOTE - fuse with 3A blade fuse near the battery.
- Ground, 0V (-) (see ① in Figure 5).

Outputs/functions

- Output/Connection 1 - Winch 1 In
- Output/Connection 2 - Winch 1 Out

10 Indicators on the Receiver

10.1 LED Indicators

The receiver has LED indicators that indicate different parameters (see Figure 1, for positions of the LEDs).

The indications on the LEDs are as follows:

Power LED (①)

Indicates whether the receiver is powered.

LED 5 Squelch (⑤)

Indicates a detected signal on the operating frequency band.

LED 6 Status (⑥)

Indicates that information from a transmitter paired with the receiver has been received.

LED 7 Learn (⑦)

Indicates if the transmitter is in “Learn” Mode.

10.1.1 Outputs LED's

Indicates the state of outputs 1-6. Output LED 1 is at the bottom, output LED 6 is at the top. An activated output is indicated by a LED in ON state. (see ⑩ in Figure 1).

Table 5. Output LEDs connected to the functions

Outputs LED's	1	2	3	4	6
Function	Winch 1 In	Winch 1 Out	Winch 2 In	Winch 2 Out	Remaining ex. Lamp

10.1.2 LED's External Input Card

Table 6. LED's on input card

LED	1	2	3	4
Function	Winch 2 Out	Winch 2 In	Winch 1 Out	Winch 1 In

10.1.3 LED's for Forestry Winch

Table 7. Output LEDs connected to the functions

Output LED	1	2
Function	Winch 1 In	Winch 1 Out

11 Installation of the Receiver

The permanent installation of the receiver must include fuses that protect the equipment and wiring from over current and short-circuit. The power supply to the receiver must be fused with a 3A blade fuse.

11.1 Mounting Steps:

Step 1

Select a location that is within the environmental limitations of the receiver (see Table 1). Drill 4 holes (for measures see Figure 9) and mount the receiver with suitable screws. Mount the receiver with the cable glands facing downwards. Avoid mounting the receiver near battery, fuel line, fuel tank or exhaust manifold.

Step 2

Connect wiring for output signals and power supply. See description for each receiver. Use cable ties to secure the wires and ensure that the wiring will not be affected by abrasion, heat and/or exhausts.

Ensure that wiring to all components is correct and all loose wires are cable tied and secure. The system is now active and ready to use.

If the outputs are to be powered by the same 12/24 V DC supply as the receiver card, place a jumper between the Output Power Input (see ④ in Figure 1) and Positive (+) 12/24 V DC using a 0,75 mm² cable (see Figure 6).

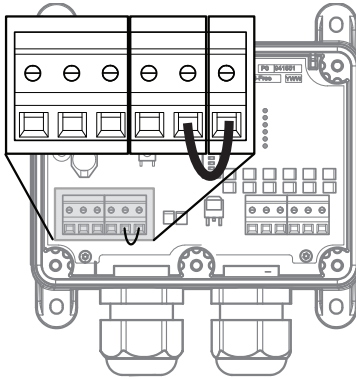









Figure 6. Configuring internal supply of output power

The relationship between buttons and outputs are described in table 8.





Table 8. Relationship between buttons and outputs

Output	1	2	3	6	4
Button	 M6  M4	 M6  M4	 M6	 M6  M6	 M6

M6:

Button 5, output 6: is an alternating function that fits the control of lights, etc.



Step 3

1. Press button 2 ( / ) on the transmitter until the green indicator lights. The transmitter is now active.
2. Press the Learn / Erase button on the receiver until LED 7 is ON.
3. The Learn Mode will be active for 10 seconds (as long as LED 7 is ON).
4. Press transmitter button 1 ( M6 or  M4) to pair the transmitter to the receiver.
5. LED 7 blinks three times if the learning has succeeded.
6. Install the receiver cover and tighten the six screws to 2.0 Nm
7. Mount the caps over the screws.

If any part of the system has been replaced, the receiver and transmitter will need to be paired together. Follow step 3 instructions.

Step 4

System Check

1. Press button 2 ( / ) on the transmitter until the green indicator lights. The transmitter is now active.
2. By pressing the transmitter button, verify that the winch in and out functions work.

12 Description of the Transmitter

Sesam 800 M6, 6 button transmitter

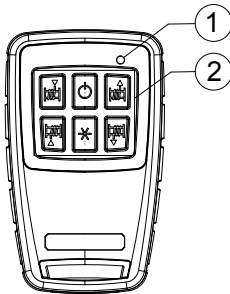
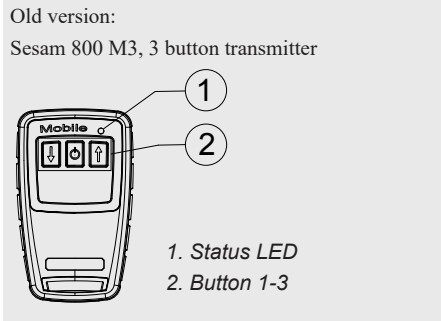
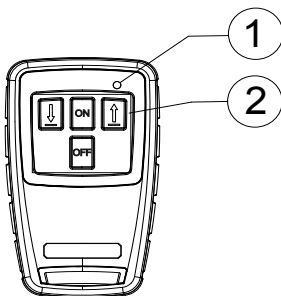

Figure 7. Sesam 800 M6 transmitter indication and buttons.

- 1. Status LED
- 2. Button 1-6

Sesam 800 M4, 4 button transmitter



- 1. Status LED
- 2. Button 1-3

Figure 8. Sesam 800 M4 transmitter indication and buttons.

- 1. Status LED
- 2. Button 1-4

13 Indications on the Transmitter

The transmitters are equipped with a status LED indicating the status of the transmission during operation (see Figure 7 and Figure 8).

13.1 Normal Operation

Quick flashing RED LED = Output is not activated and there is no feedback from the receiver.

Quick flashing RED then a continuous GREEN LED = Output is activated in the receiver with feedback.

13.2 Battery Warning



Continuous RED LED after activating a command = Low battery.

3 long RED LED flashes = Battery depleted, transmitter cannot send commands.

14 Operation

14.1 Activating the Transmitter



The transmitter is delivered with the batteries not installed. Insert the batteries according to chapter 16.

Activate the transmitter by pushing the start button ( / ) for 3 seconds. The transmitter indicator will flash GREEN quickly during startup and then flashing GREEN slowly when contact with the receiver is enabled. The transmitter is now enable to control the winch.

14.2 Deactivating the Transmitter



To prevent unintended activation the transmitter shall be turned off when not used.











Turn off the transmitter by pushing button 2/5 (/) for three seconds; the indicator flashes a couple of quick RED to finish with a long RED. The transmitter is now turned off.

If you forget to turn off the transmitter it will shut itself off after a time, idle-time (non-use).

14.3 Controlling the Device

The winch is controlled via the buttons on the transmitter.

The relationship between buttons and outputs are:

- Button 1 (/) , Winch 1 in.
- Button 2 (/) M6:ON/OFF M4:ON function (3 sec.).
- Button 3 (/) , Winch 1 out.
- Button 4 (), Winch 2 in.
- Button 5 (/) , M6:Remaining function ex. lamp. M4:OFF_(3sec.).
- Button 6 (), Winch 2 out.

15 Receiver Drill Measures

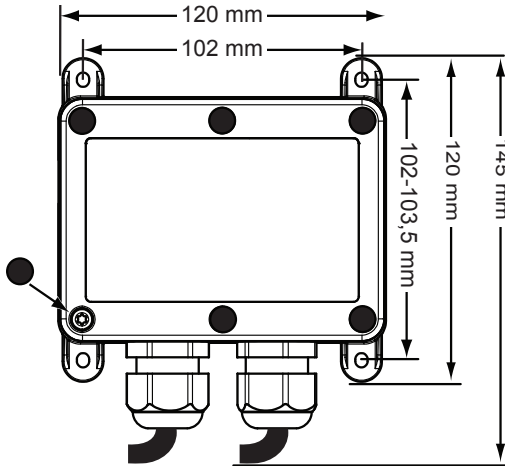

Figure 9. Receiver Drill Measures

The receiver shall be attached with 4 mm screws that are suitable for the surrounding environment

16 Replacing Batteries in Sesam 800 M6 & M4

If the status indicator on the transmitter indicates low battery, replace the batteries promptly. Before changing the batteries note that changing of batteries must take place in a clean environment free from static electricity.

The batteries are changed as follows:

1. Open the battery cover by unscrewing the 6 screws on the backside of the transmitter cover with screwdriver PH2.
2. Carefully remove the cover by lifting up the front of the cover.
3. Remove the used batteries
4. Insert new batteries. Make sure the batteries are inserted in the correct polarity.
5. Close the cover by first inserting the backside of the cover in the transmitter, and then pushing the front down.
6. Tighten the 6 screws with torque 1.0 Nm.

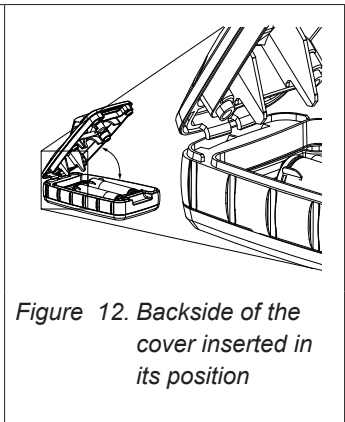
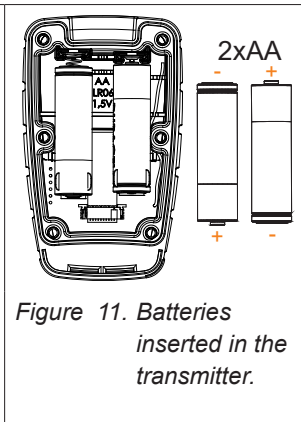
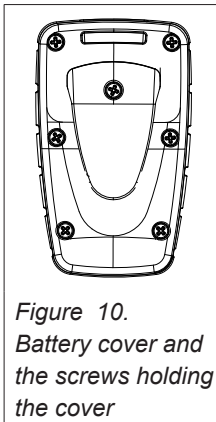



Åkerströms Björbo AB | Box 7, Björbovägen 143 | SE-786 97 Björbo, Sweden
Phone +46 241 250 00 | frontoffice@akerstroms.se | www.akerstroms.se